



1675 MacArthur Blvd., Costa Mesa, CA, 92626 USA
 Main Number (714) 754-6175 Sales & Marketing (714) 957-7100 or toll free (USA only) (800) 854-4079
 Customer Service (714) 957-7150 or toll free (USA only) (800) 772-2834

Cinema Mid-High Loudspeaker System User Manual

MH-1063 10" (254mm) mid, 2.5" (63mm) compression driver

MH-1075 10" (254mm) mid, 3.0" (75mm) compression driver

Introduction

The MH-1063 and MH-1075 "mid-high packs" provide the mid and high frequency components of three-way screen channel loudspeaker systems for high performance cinema applications. They were designed to operate with and be directly mounted on QSC's cinema low frequency enclosures.

Mid frequencies are reproduced with a 10" (254mm) high-efficiency, phase-ring loaded driver mounted on a custom designed cinema horn. The high-frequency driver is a large format, 2.5" (63mm, MH-1063) or 3.0" (75mm, MH-1075) titanium diaphragm compression driver mounted on a custom high-frequency cinema horn. The high frequency horn is a low-distortion waveguide providing highly articulate dialogue without coloration associated with conventional horn loudspeakers. Both horns feature broad horizontal and vertical coverage angles to ensure coverage of every seat in the auditorium. The driver assemblies are mounted on an adjustable pan and tilt bracket that has an integral aiming sight, simplifying installation.

The MH-1063 and MH-1075 loudspeakers include a driver protection and crossover network to assure reliable operation. DC blocking capacitors protect against DC or low-frequency signals that could damage an unprotected driver. Power limiter circuitry protects the driver from over-powering and an 18dB/octave crossover seamlessly blends the high and mid frequency elements. Outboard processing is required to form the crossover between the LF and MH loudspeakers.

Bi-amp or tri-amp operation is possible using a selector switch mounted on the connections panel. The bi-amp setting provides a passive crossover network between mid and high drivers. Separate amplifiers and an active crossover are required for the low frequency channel and the mid-high channel. Tri-amp setting disables the internal mid-high crossover and each driver is driven independently by its own amplifier and active crossover; one for the low, one for the mid, and one for the high frequencies.

The MH-1063 and MH-1075 components come pre-assembled to reduce field assembly time. Three bolts are all that are required to secure the mid-high assembly to the top of a QSC low frequency enclosure.

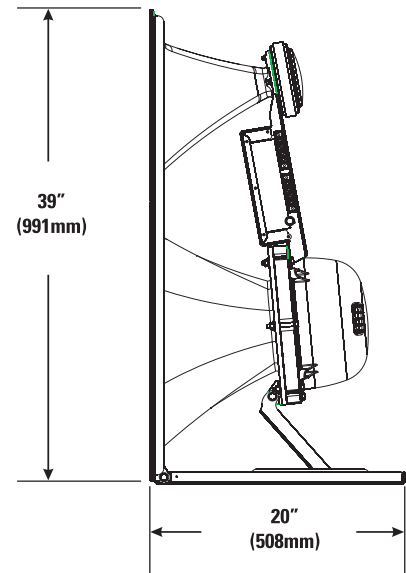
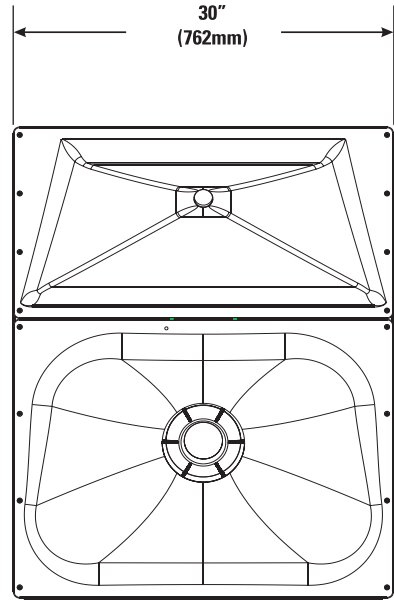
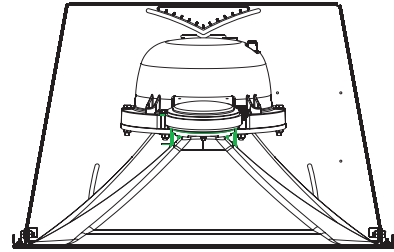

Install in accordance with QSC Audio Product's instructions and a licensed, professional engineer. Only use attachments, mounts, accessories, or brackets specified by QSC Audio Products, Inc. Refer all servicing to qualified personnel. Servicing is required when the apparatus has been damaged in any way.



WARNING! Before placing, installing, rigging, or suspending any speaker product, inspect all hardware, suspension, cabinets, transducers, brackets and associated equipment for damage. Any missing, corroded, deformed or non-load rated component could significantly reduce the strength of the installation, placement, or array. Any such condition severely reduces the safety of the installation and should be immediately corrected. Use only hardware which is rated for the loading conditions of the installation and any possible short-term unexpected overloading. Never exceed the rating of the hardware or equipment. Consult a licensed, professional engineer when any doubt or questions arise regarding a physical equipment installation.



Mounting

Attaching to Low Frequency Enclosure

The mid-high loudspeaker assembly attaches to the top of the QSC low frequency cabinet with three 5/16-18 bolts, 0.75" long, with lock washers. This hardware ships installed on the low frequency cabinet. We recommend the use of serviceable thread locking compound when installing the bolts to prevent loosening due to vibration. Do not fully tighten the mounting hardware before aiming (see below).

Aiming

Aim the horn in the horizontal plane (pan) before tightening the attachment hardware. Adjust the vertical tilt with the mid-high vertical adjustment bracket. The mid-high assembly is equipped with an aiming sight to assist in achieving desired coverage quickly and easily. For typical applications, the aim point should be the center seat in the back row of the auditorium. If the cinema screen has already been installed, a flashlight placed at the desired aiming point can be seen through the screen perforations in a darkened auditorium.

Where the sight holes are located:

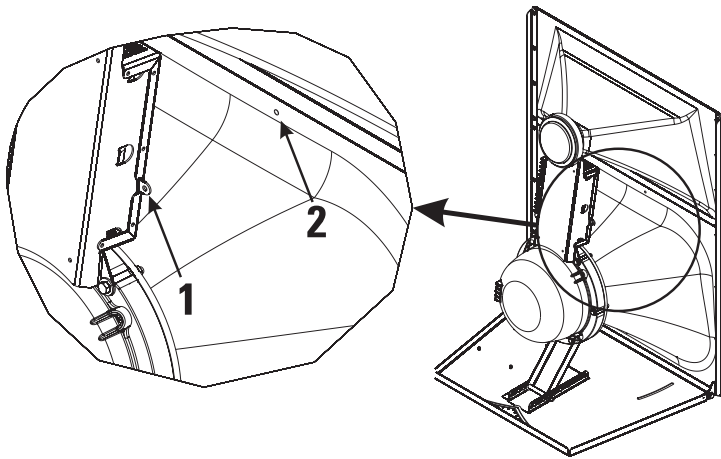

How to use the sights:

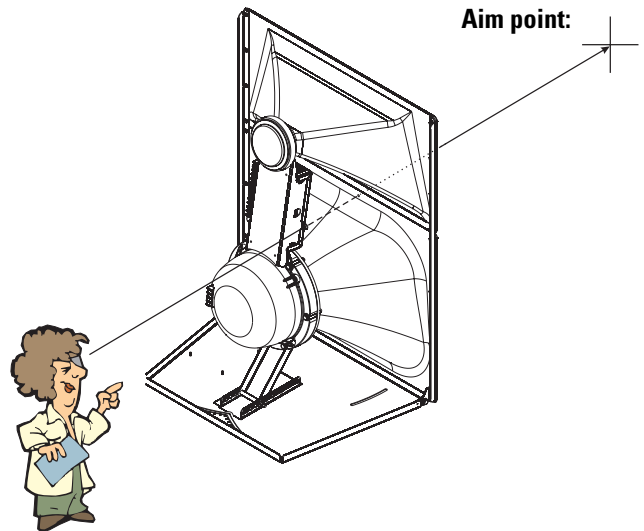

Settings

BI-AMP / TRI-AMP Operating Mode Selection

Set the operating mode selector switch to **BI-AMP** or **TRI-AMP**, depending on your application setup.

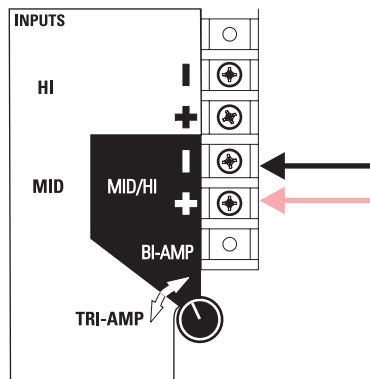

BI-AMP-When set to **BI-AMP**, the MH-1063 and MH-1075 accepts mid-high frequency signals on one set of inputs and uses an internal crossover network between the mid- and high-frequency drivers. The signal applied to the mid-high loudspeaker assembly must not contain low-frequency content (below 200 Hz).

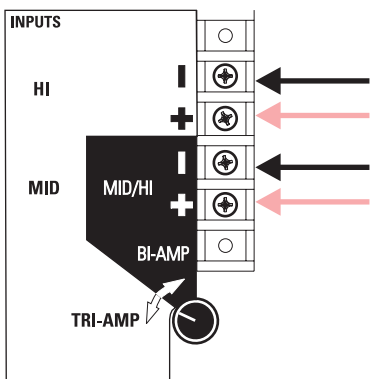

TRI-AMP- When set to **TRI-AMP**, the MH-1063 and MH-1075 accepts separate mid- and high-frequency signals on two sets of inputs. The internal crossover network is bypassed and only the protective circuitry for the H.F. driver remains. Each of the driver's signals must have the appropriate signal processing before operating.



**Do not connect amplifiers directly to the driver inputs!
Always use the input terminal strip.**

Connections

INPUT Terminals

The MH-1063 and MH-1075 have barrier strip screw terminals that accept up to #10 AWG (5.3mm²) stranded loudspeaker wire. Observe proper polarity. Use the largest wire size and shortest wire length for the application.

OUTPUT Terminals

The **OUTPUT** terminals are factory-connected to the drivers. These terminals should **ONLY** be connected to their respective driver. Do not connect signals to these terminals as all protection and equalization circuitry will be bypassed.



NOTE! Maintain proper loudspeaker connection polarity throughout the entire system for maximum performance. Do not apply full range signal to the MH-1063 / MH-1075! There is a mid-high passive crossover for bi-amp mode only. There is no crossover connected when operating in tri-amp mode. A protection network is always active. All required signal processing must be done before the signal is applied to the loudspeaker. Do not connect any signal to the upper sets of OUTPUT terminals.

BI-AMP mode connections- Ensure the mode switch is set to **BI-AMP**, connect the input to the MH-1063 / MH-1075 to the lower set of input terminals marked "**BI-AMP + -**".

BI-AMP Mode- one amplifier channel is used for the low frequency cabinet and one amplifier channel for the mid-high assembly. The MH-1063 / MH-1075 mode switch is set to **BI-AMP**. Active crossovers are used before amplification. The mid-high assembly provides a passive crossover between the mid and high frequency drivers.

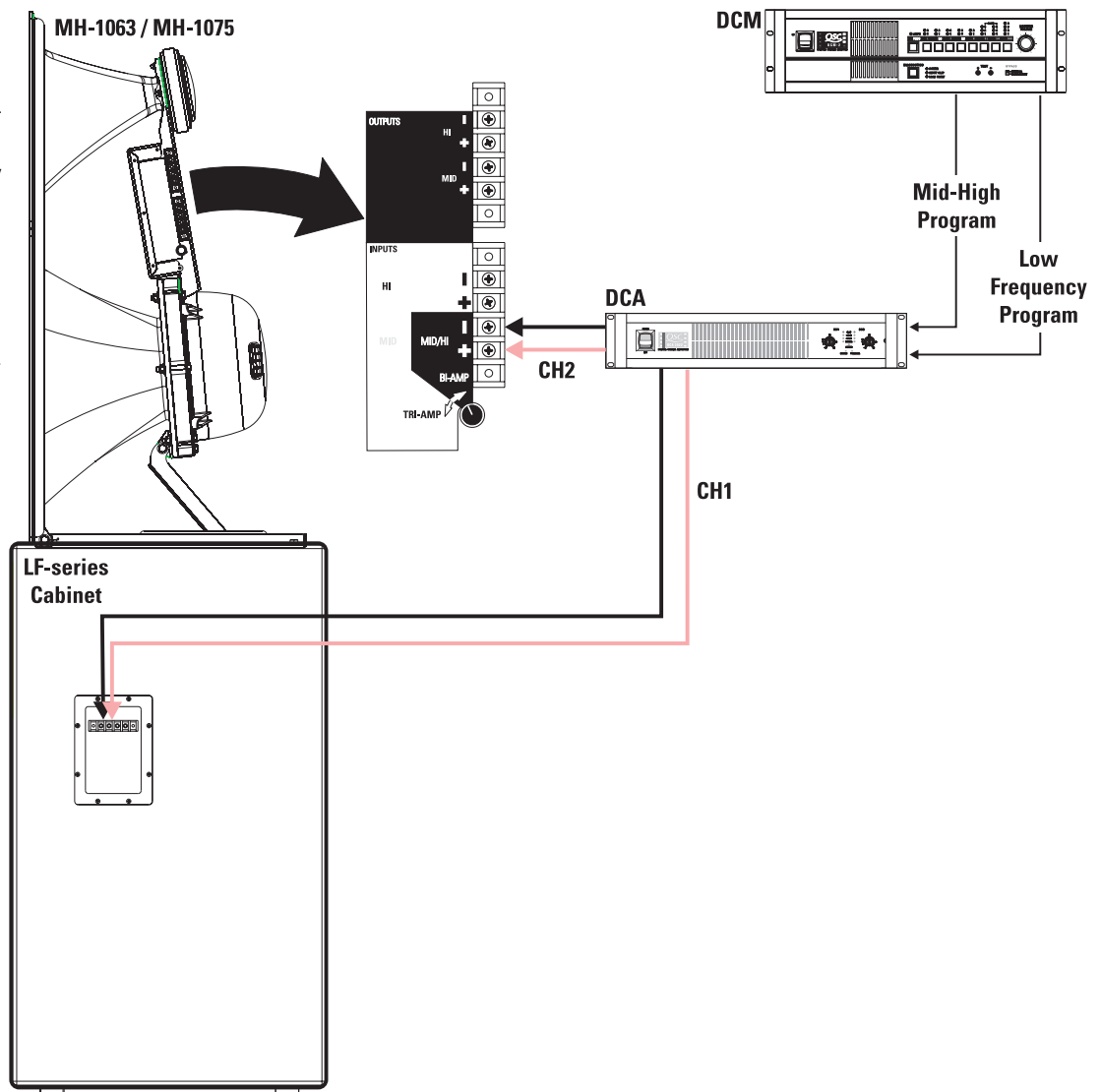

Connections (continued)

TRI-AMP mode connections- When the mode switch is set to **TRI-AMP**, connect the high frequency signal to the terminals marked "INPUT HI + -" and the mid frequency signal to the terminals marked "INPUT MID + -".

TRI-AMP Mode- one amplifier channel is used for the low frequency cabinet, one amplifier channel for the mids, and one amplifier channel for the high frequencies. The MH-1063 / MH-1075 mode switch is set to **TRI-AMP**, bypassing the internal mid-high passive cross-over. Active or passive crossovers are used before amplification. Power limiter and DC blocking remain active.

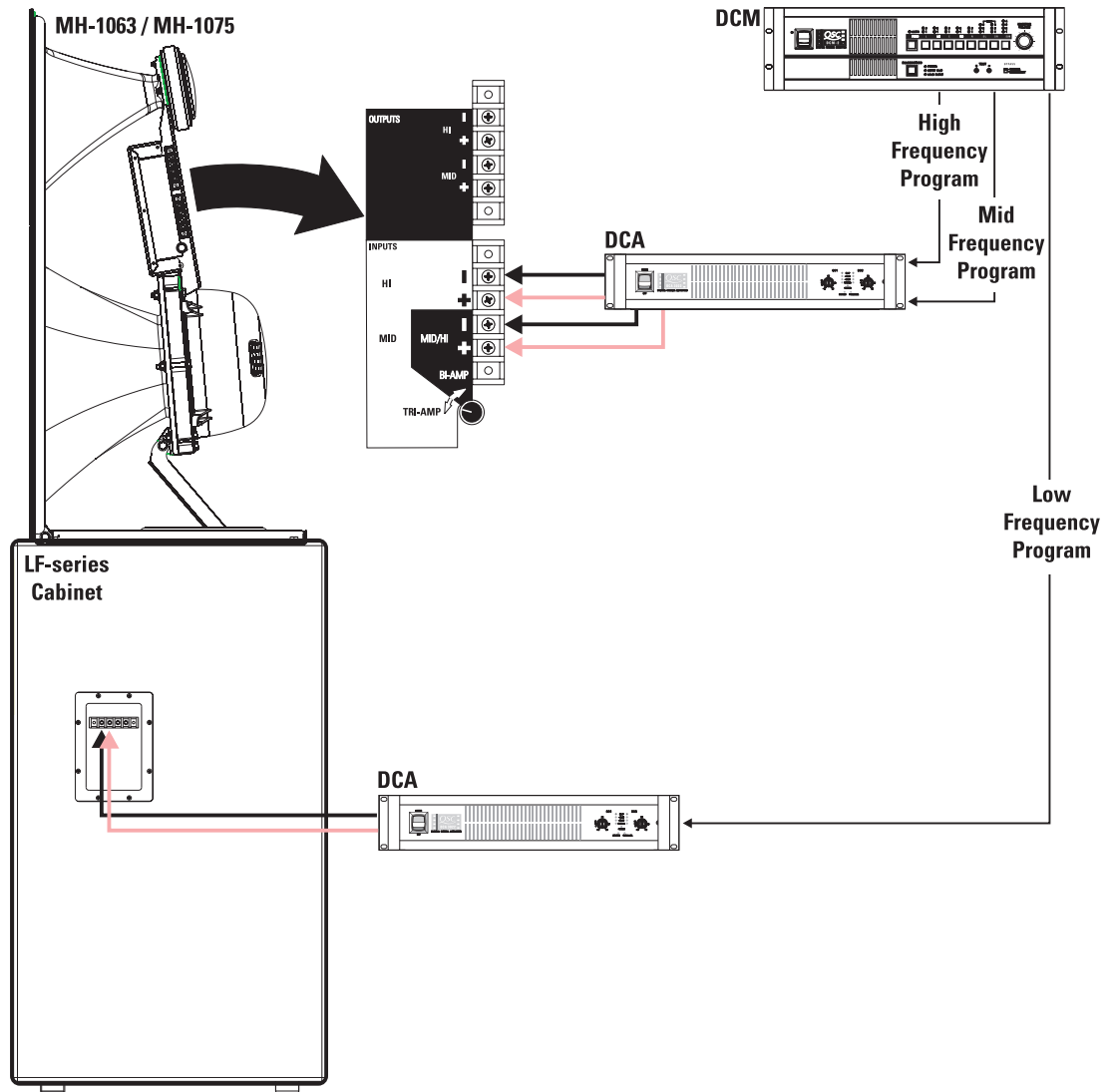

MH-1063 Specifications (subject to change without notice)

Freq. Range	180 - 15k (-6dB, full space)
Nominal Coverage	90° horizontal X +20 to -30° vertical (50° total, adjustable mount provides for vertical plane adjustments. The horizontal plane can be adjusted by altering mounting position on the low frequency enclosure before tightening bolts.
DI:	9 dB (400 to 16k Hertz average)
Q:	8 (400 to 16k Hertz average)
Max. Output:	[Tri-amp mode] Mid Freq. 135.5 dB SPL calculated peak, 1m, full space [Tri-amp mode] High Freq. 131.5 dB SPL calculated peak, 1m, full space [Bi-amp mode] 135 dB SPL calculated peak, 1m, full space
Impedance:	[Bi-amp mode] 8 ohms nominal 7.9 ohms minimum at 1500 Hertz 91 ohms maximum at 150 Hertz
Maximum Input Power	[Tri-amp mode] Mid Freq. 275 W (AES method, 2 hrs.) [Tri-amp mode] High Freq. 60 W (AES method, 2 hrs.) [Bi-amp mode] 250 W (IEC method, 8 hrs.)
Sensitivity	[Tri-amp mode] Mid Freq. 105 dB SPL, 1 watt, 1 meter [Tri-amp mode] High Freq. 107.5 dB SPL, 1 watt, 1 meter [Bi-amp mode] 135 dB SPL, 1 watt, 1 meter
Crossover Frequency	[Tri-amp mode] 250 Hertz or higher, 24dB/octave and 1.7k Hertz, 24dB/octave [Bi-amp mode] 250 Hertz or higher, 24dB/octave
Crossover Network	1.7k Hertz, 18 dB/octave electrical slope, HF driver power limiting circuit (never disrupts continuity). Switchable operation between Bi-Amp and Tri-amp operation. Tri-amp setting removes crossover circuit from signal, leaving power limiter and DC blocking capacitors.
Connectors	Barrier strip screw terminals accept up to #10 AWG stranded wire. Four terminals, two HF input and two MF input (for Tri-amp mode operation).
Transducers	MF: 10" high efficiency midrange, phase-ring loaded. HF: 1.5" (38mm) exit, 2.5" (63.5mm) titanium diaphragm compression driver.
Mounting Hardware:	Attaches to top of the low frequency cabinet using three 5/16"-18 x 3/4" long bolts.
Size	39" high x 30" wide x 20" deep (991 x 762 x 508mm)
Weight	85 lb. (39 kg) net

MH-1075 Specifications (subject to change without notice)

Freq. Range	180 - 15k (-6dB, full space)
Nominal Coverage	90° horizontal X +20 to -30° vertical (50° total, adjustable mount provides for vertical plane adjustments. The horizontal plane can be adjusted by altering mounting position on the low frequency enclosure before tightening bolts.
DI:	9 dB (400 to 16k Hertz average)
Q:	8 (400 to 16k Hertz average)
Max. Output:	[Tri-amp mode] Mid Freq. 135.5 dB SPL calculated peak, 1m, full space [Tri-amp mode] High Freq. 133 dB SPL calculated peak, 1m, full space [Bi-amp mode] 135.5 dB SPL calculated peak, 1m, full space
Impedance:	[Bi-amp mode] 8 ohms nominal 6.4 ohms minimum at 1500 Hertz 91 ohms maximum at 150 Hertz
Maximum Input Power	[Tri-amp mode] Mid Freq. 275 W (AES method, 2 hrs.) [Tri-amp mode] High Freq. 80 W (AES method, 2 hrs.) [Bi-amp mode] 250 W (IEC method, 8 hrs.)
Sensitivity	[Tri-amp mode] Mid Freq. 105 dB SPL, 1 watt, 1 meter [Tri-amp mode] High Freq. 108 dB SPL, 1 watt, 1 meter [Bi-amp mode] 135.5 dB SPL, 1 watt, 1 meter
Crossover Frequencies	[Tri-amp mode] 250 Hertz or higher, 24dB/octave and 1.7k Hertz, 24dB/octave [Bi-amp mode] 250 Hertz or higher, 24dB/octave
Crossover Network	1.7k Hertz, 18 dB/octave electrical slope, HF driver power limiting circuit (never disrupts continuity). Switchable operation between Bi-Amp and Tri-amp operation. Tri-amp setting removes crossover circuit from signal, leaving power limiter and DC blocking capacitors.
Connectors	Barrier strip screw terminals accept up to #10 AWG stranded wire. Four terminals, two HF input and two MF input (for Tri-amp mode operation).
Transducers	MF: 10" high efficiency midrange, phase-ring loaded. HF: 1.5" (38mm) exit, 3" (76mm) titanium diaphragm compression driver.
Mounting Hardware:	Attaches to top of the low frequency cabinet using three 5/16"-18 x 3/4" long bolts.
Size	39" high x 30" wide x 20" deep (991 x 762 x 508mm)
Weight	85 lb. (39 kg) net

MH-1063 SPL and Impedance vs. Frequency

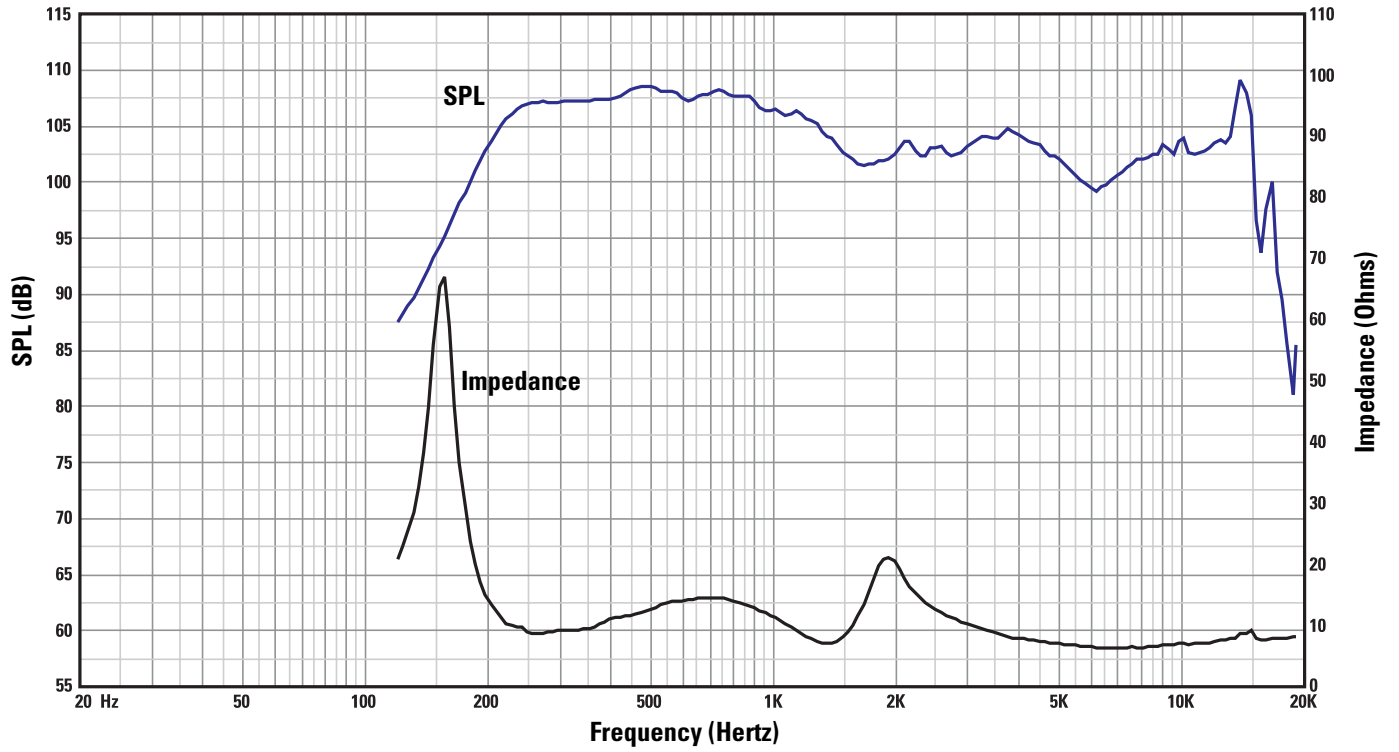

MH-1075 SPL and Impedance vs. Frequency

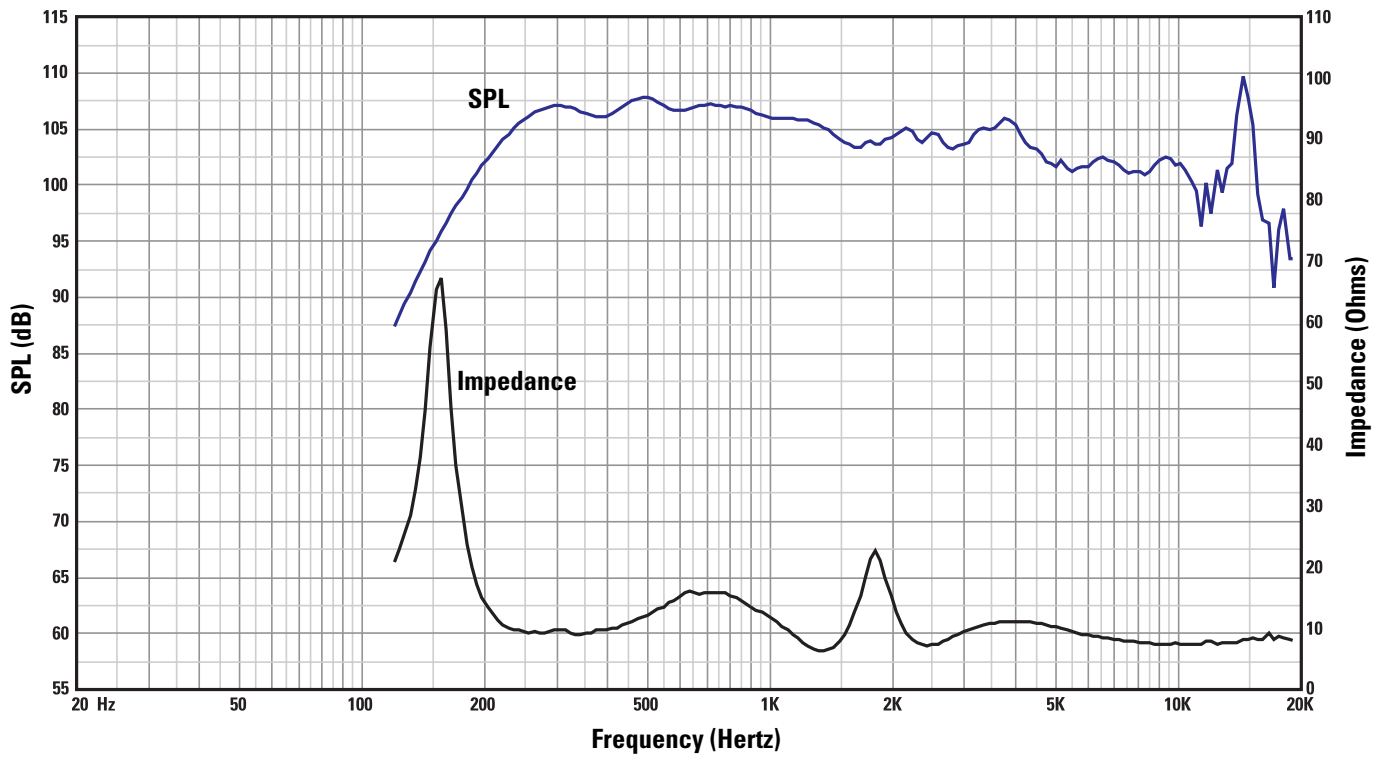

Warranty (USA only; other countries, see your dealer or distributor)

Disclaimer

QSC Audio Products, Inc. is not liable for any damage to amplifiers, or any other equipment that is caused by negligence or improper installation and/or use of this loudspeaker product.

QSC Audio Products 3 Year Limited Warranty

QSC Audio Products, Inc. ("QSC") guarantees its products to be free from defective material and / or workmanship for a period of three (3) years from date of sale, and will replace defective parts and repair malfunctioning products under this warranty when the defect occurs under normal installation and use - provided the unit is returned to our factory or one of our authorized service stations via pre-paid transportation with a copy of proof of purchase (i.e., sales receipt). This warranty provides that the examination of the return product must indicate, in our judgment, a manufacturing defect. This warranty does not extend to any product which has been subjected to misuse, neglect, accident, improper installation, or where the date code has been removed or defaced. QSC shall not be liable for incidental and/or consequential damages. This warranty gives you specific legal rights. This limited warranty is freely transferable during the term of the warranty period.

Customer may have additional rights, which vary from state to state.

In the event that this product was manufactured for export and sale outside of the United States or its territories, then this limited warranty shall not apply. Removal of the serial number on this product, or purchase of this product from an unauthorized dealer, will void this limited warranty. Periodically, this warranty is updated. To obtain the most recent version of QSC's warranty statement, please visit www.qscaudio.com. Contact us at 800-854-4079 or visit our website at www.qscaudio.com.

Contacting QSC Audio Products

Mailing address: QSC Audio Products, Inc.
1675 MacArthur Boulevard
Costa Mesa, CA 92626-1468 USA

Telephone Numbers:

Main Number (714) 754-6175

Sales & Marketing (714) 957-7100 or toll free (USA only) (800) 854-4079

Customer Service (714) 957-7150 or toll free (USA only) (800) 772-2834

Facsimile Numbers:

Sales & Marketing Fax (714) 754-6174

Customer Service Fax (714) 754-6173

World Wide Web: www.qscaudio.com

E-mail: info@qscaudio.com

service@qscaudio.com

