



AcousticCoverage™ Series

AC-C4T-nb, AC-C8T-nb

Full range ceiling mount loudspeaker,
with no back can (nb)

Features

- High quality transducers provide exceptional clarity through the critical voice range.
- Improved musicality often not seen in typical BGM class products.
- Low-saturation 70/100V transformers with 8-ohm bypass.
- Advanced voicing via QSC Intrinsic Correction™, applied using the Q-SYS™ Platform or CXD Series amplifier platforms.
- White (RAL 9010) with UV inhibitors to match complementing QSC product families.
- Complete EASE, CF2, CAD, & BIM information available online.

AC-C4T-nb
AC-C8T-nb



Wide Area Paging · Background Music · Distance Conferencing Reinforcement · Healthcare Facilities · Concourses · Transportation Terminals · Ancillary Support in Larger Systems

The QSC AcousticCoverage™ Series “no back can” models (nb) are full-range 4.5 and 8 inch ceiling-mounted loudspeakers. Each comes with a 70/100V transformer and is suitable for a wide variety of audio/video conferencing reinforcement, voice paging and background music applications.

The AcousticCoverage™ Series offers integrators a cost-effective solution for voice reinforcement applications, while also providing an improved musicality typically paging/BGM products.

The high-quality weather treated paper cone transducer features a whizzer cone to improve high frequency dispersion throughout the critical vocal range and maintain speech intelligibility. The wide dispersion angle lets you cover an area evenly with fewer loudspeakers, even in low-ceiling applications.

The easy-to-install blind mount assembly features a system of four dog-ears,

located under the torsion-fit powder coated steel grille.

The 6-watt low-saturation, low-loss 70/100V transformers have color coded bare wire terminations to avoid the cost of rotary selectors.

For enhanced performance and speedy installs, implement model-specific advanced voicing through QSC Intrinsic Correction. QSC Intrinsic Correction™ is available in the Q-SYS™ Platform and in CXD Series amplifiers.

The AC-C4T-nb and AC-C8T-nb come in QSC standard white (RAL 9010) to match complementing QSC product families. UV inhibitors in the pigment prevent discoloration over time. The loudspeakers may also be painted to match any décor.

For your system integration needs, complete EASE, CF2, CAD, and BIM files are available for download at QSC.com.

AC-C4T-LP/ AC-C8T-LP Details

Dimensions

AC-C4T-nb

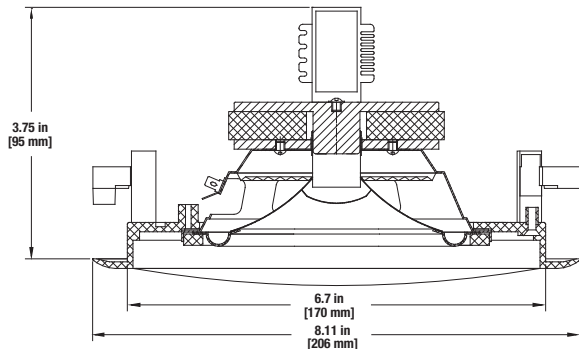

AC-C8T-nb

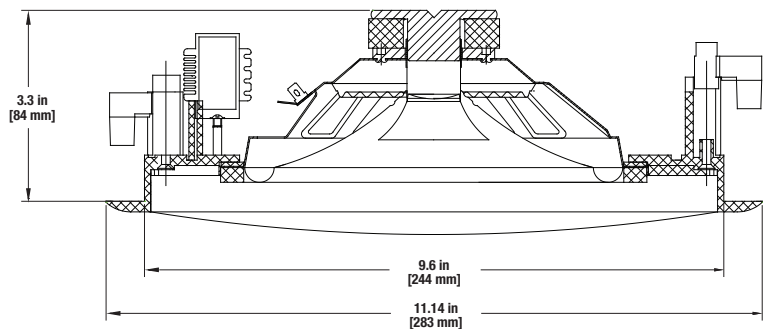

Specifications

	AC-C4T-nb	AC-C8T-nb
Transducer	100 mm [4 in.] weather treated paper cone	200 mm [8 in.] weather treated paper cone
Rated noise power [continuous] ⁽¹⁾	6 W	6 W
Nominal Impedance	8Ω	8Ω
Transformer Taps	70V: 6, 3, 1.5, 0.75 W 100V: 6, 3, 1.5 W	70V: 6, 3, 1.5, 0.75 W 100V: 6, 3, 1.5 W
Effective frequency range ⁽²⁾	62 Hz – 18 kHz	53 Hz – 20 kHz
Rated coverage ⁽³⁾	140° conical	130° conical
Directivity factor	4	5.6
Directivity index [dB]	6	7.5
Sensitivity ⁽⁴⁾	93 dB	96 dB
Maximum continuous SPL ⁽⁵⁾	101 dB	104 dB
Maximum peak SPL ⁽⁵⁾	107 dB	110 dB
Baffle material	ABS	ABS
Grille material	Powder coated steel	Powder coated steel
Cutout dimension	Ø 178 mm [Ø 7 in]	Ø 254 mm [Ø 10 in]
Net weight	1.2 kg [2.6 lb]	1.5 kg [3.4 lb]
Product dimensions (Diameter x Height)	Ø 206 x 95 mm [Ø 8.11 x 3.75 in]	Ø 283 x 84 mm [Ø 11.14 x 3.3 in]
Shipping weight	5.9 kg [13.1 lb] (packs of 4)	7.8 kg [17.3 lb] (packs of 4)
Shipping dimensions (H x W x D)	254 x 324 x 476 mm [10 x 12.75 x 18.75 in] (packs of 4)	343 x 324 x 635 mm [13.5 x 12.75 x 25 in] (packs of 4)

- 1 AES2-1984 noise signal for 2 Hr, 8Ω
- 2 Free-field, -10 dB from on-axis sensitivity
- 3 -6 dB from on-axis, 500 Hz–5 kHz
- 4 Free-field, on-axis, 2.83V, 1 m
- 5 Calculated from rated noise voltage and sensitivity

As part of QSC's ongoing commitment to product development, specifications are subject to change without notice.



1675 MacArthur Boulevard • Costa Mesa, CA 92626 • Ph: 800/854-4079 or 714/957-7100 • Fax: 714/754-6174

© 2016 QSC, LLC all rights reserved. QSC and the QSC logo are registered trademarks of QSC, LLC in the U.S. Patent and Trademark office and other countries. AcousticCoverage, Intrinsic Correction and Q-SYS are trademarks of QSC. All other trademarks are the property of their respective owners. Patents may apply or be pending.

AC-C4T-LP / AC-C8T-LP Spec Sheet 12/02/2016

